

# solartron

---



digital readout

installation manual



model  
no. DR600  
DR700

# 1.0: Index

---

Section	Title	Page
1.0	Index . . . . .	1
2.0	Safety Summary . . . . .	2
3.0	Service & Repair . . . . .	4
4.0	Measurement Configurations . . . . .	5
5.0	Digital Readout Interface . . . . .	6
6.0	Probe Interface/Orbit Network Connections . . . . .	8
7.0	RS232 . . . . .	9
8.0	Input/Output Connections . . . . .	12
9.0	Motor Drive Connections . . . . .	16
10.0	General Specification . . . . .	17
11.0	Return of Goods . . . . .	18

## 2.0: Safety Summary

---

This Equipment is designed as Safety Class I apparatus to comply with EN61010-1.

### Service Safety

This equipment has been designed and tested to meet the requirements of the Low Voltage Directive (1997) and has been supplied in a safe condition.

This manual contains information and warnings that must be followed by the user to ensure safe operation and to retain the apparatus in a safe condition.

### Terms in this Manual

**WARNING** statements identify conditions or practices that could result in personal injury or loss of life.

**CAUTION** statements identify conditions or practices that could result in damage to the equipment or other property.

### Symbols in this Manual



This symbol indicates where applicable cautionary or other information is to be found.

### Power source

Apply no more than 265V rms (AC) between supply conductors or conductor and ground.

## 2.0: Safety Summary (continued)

---

**WARNING: Do not operate in an explosive atmosphere**

**WARNING: Do not remove covers or panels**

To avoid personal injury, do not remove covers and panels. Do not operate the equipment without the covers and panels fitted. There are no internal adjustments required during commissioning the equipment.

**Warning: Danger arising from loss of ground**

During a fault condition and upon loss of protective ground (earth) connection, all accessible conducting parts - including controls that might appear to be insulated - can render an electric shock.

**CAUTION: Use correct Fuse**



To avoid a fire hazard, use the correct fuse type, voltage and current rating as specified for the equipment. Refer fuse replacement to qualified service personnel.

**Grounding the equipment**

The unit is grounded through the mains lead: to avoid electric shock, plug the power lead into a properly-wired receptacle before connecting to the input or output terminals. A protective ground connection by the way of the grounding conductor in the power lead is essential for safe operation.

## 3.0: Service & Repair

---

### Replacing the fuse



At the rear right of the Digital Readout remove the fuse cover of the IEC320 connector and replace the fuse with the same 20mm type and value.

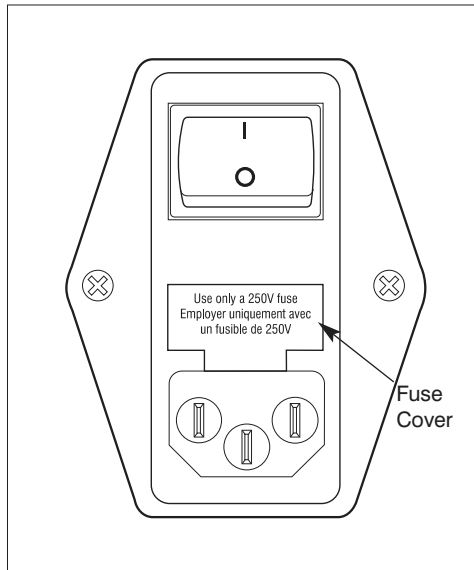

**This equipment contains no user serviceable parts other than the fuse.**

This equipment must be returned to your Solartron dealer for all other service and repair.

Dismantling the unit will invalidate the warranty.

# 4.0: Measurement Configurations

---

**Individual probe** - connection of one Linear Encoder or Digital Probe.

**Probe pair** - connection of 2 probes configured as A+B or A-B.

Probes may be plugged directly into the rear panel recessed receptacle.

**Multiple probes** - up to 10 individual probes or probe pairs (A+B or A-B) each allocated to a program.

## DR600 only

**Scan** - connection of up to 30 probes (Linear Encoders and/or Digital Probes) and allocated to a single program.

## DR700 only

**Gauging mode** - connection of up to 30 probes (Linear Encoders and/or Digital Probes) each with its own limits and preset. Global Pass/Fail.

Refer to Digital Readout User Manual to configure the options.

To connect more than 2 probes to the Digital Readout, use the Orbit Network Connection System.

When more than 10 probes are connected to the Digital Readout a supplementary power supply interface module will be required (Solartron Part No. 911173).

# 5.0: Digital Readout Interface

Probe(s) must be identified to the Digital Readout when first installed. Simply press probe tip when prompted.

## 5.1 Connecting 1 or 2 Probes

To connect a Linear Encoder or Digital Probe ensure cable from Probe Interface Electronics (PIE) is at bottom of unit and plug into either left hand or right hand side of recessed receptacle.

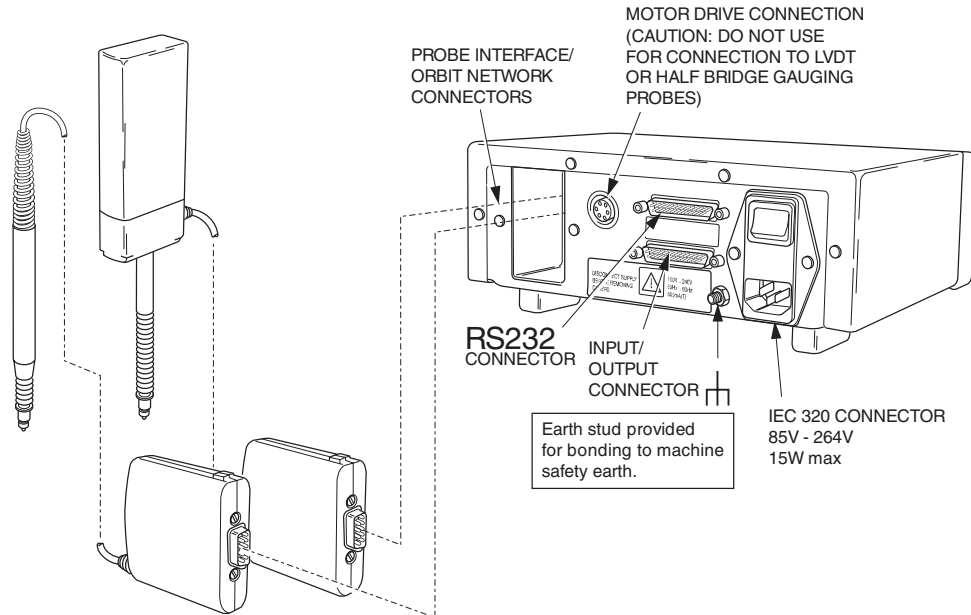

# 5.0: Digital Readout Interface (Continued)

## 5.2 Connecting up to 30 probes

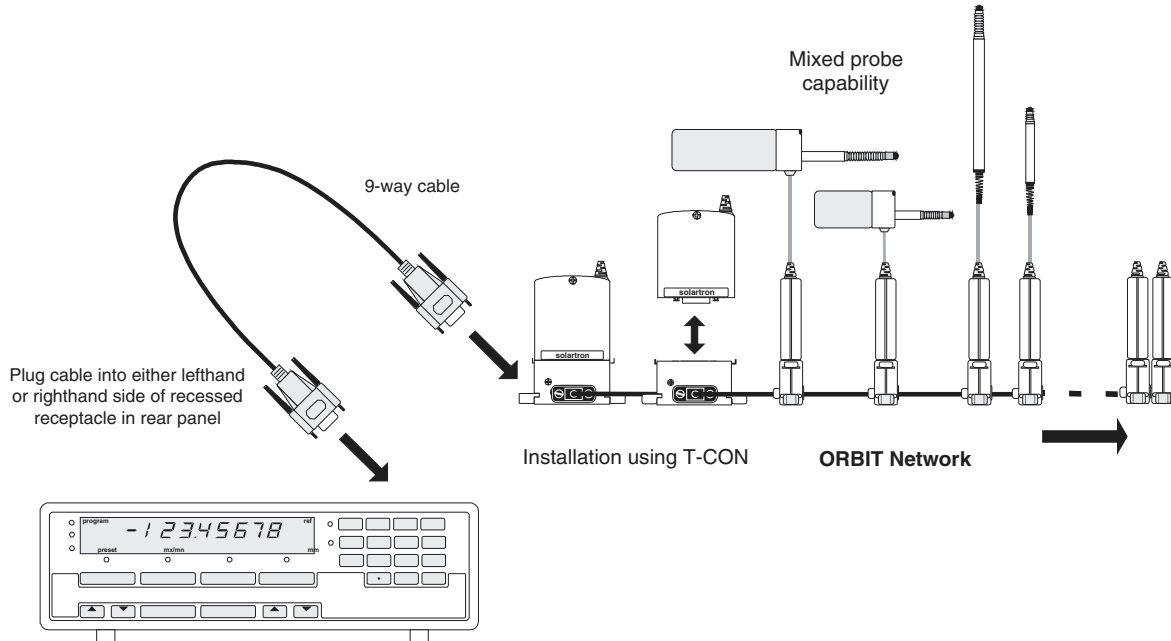

- Accessories
  - T-CON part number 971000
  - 9 pin (m/f) cable 1.5m 006869
  - 9 pin (m/f) cable 5m 803664



# 6.0: Probe Interface/Orbit Network Connections

Connector type: 9 way D-sub female

Pin	Function
1	0V
2	RS485(A)
3	RS485(B)
4	0V
5	0V
6	+5V
7	+5V
8	+5V
9	0V

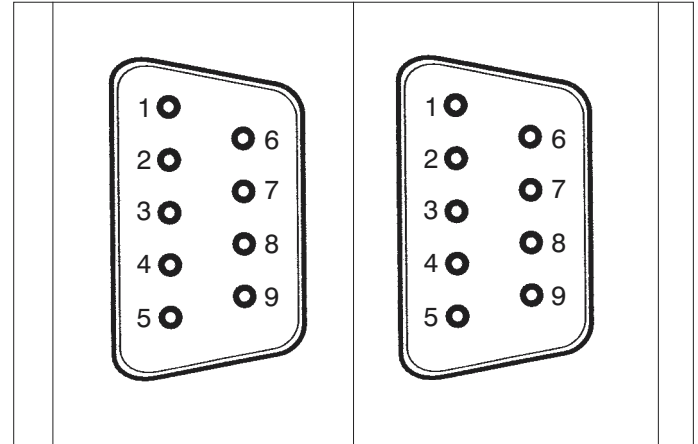

View from rear of unit

# 7.0: RS232

(Allows measurement readings to be sent to printer or PC)

Connector type 25 way D-sub female

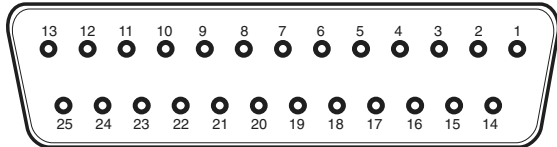

## 7.1 Pin Assignment

Pin	Signal	Assignment
1	CHASSIS GND	Chassis ground
2	TXD	Transmitted data
3	RXD	Received data
4	RTS	Request to send
5	CTS	Clear to send
6	DSR	Data set ready
7	SIGN GND	Signal ground
20	DTR	Data terminal ready

## 7.2 Voltage levels

TXD and RXD voltage levels

logic level (active) -3V to -15V

logic level (not active) +3V to +15V

RTS, CTS, DSR and DTR voltage levels

logic level (active) +3V to +15V

logic level (not active) -3V to -15V

## 7.3 Connection cable

### Simple connection between Digital Readout and printer or PC

(No flow control or Xon/Xoff flow control)

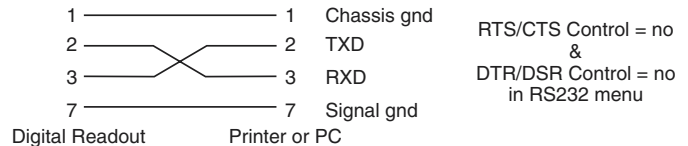

# 7.0: RS232 (Continued)

## Connection between Digital Readout & printer or PC using RTS/CTS and DTR/DSR

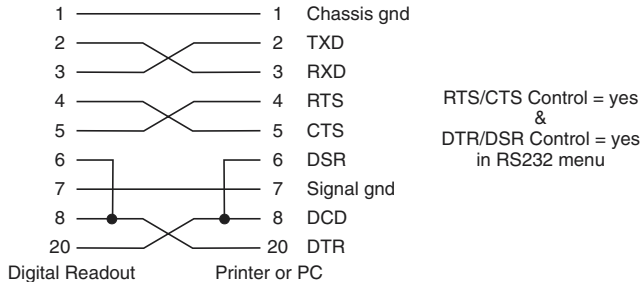

**7.4 Baud Rate**      300, 600, 1200, 2400, 4800,  
 9600, 19200, 28800, 57600

**7.5 Data Format**      1 start bit  
 7 data bits  
 none/odd/even parity  
 1 or 2 stop bits

Note: Baud rate and data format options are defined in RS232 menu. Ensure settings are the same as on the connected serial device.

## 7.6 Message format Digital Readout to PC or printer

Message: <Displayed Measurement>

Initiated by <Send Measurement> command or by pressing **print** key

1	9	10	20	21	22	23	
	Text	Reading		U	S	R	

Message terminated by [carriage return] [line feed]

### Key:

- Text: ASCII text dependant on mode of operation (Bytes 1 to 9)
- Reading: ASCII representation of the reading, leading zero's replaced by spaces (Bytes 10 to 20)
- U = units " " for inches (Byte 21)  
 space for mm
- R = range lamps '>' out of tolerance - high (Byte 23)  
 '=' in tolerance  
 '<' out of tolerance - low

### DR700 only

If scaling applied (not 1.000) S in byte 22. Blank if no scaling.

# 7.0: RS232 (continued)

---

## PC or printer to Digital Readout

Command	Character	Description
<Send Measurement> <X OFF> <X ON>	STX DC3 DC1	Requests displayed measurement to be sent Stop transmission of message Restart transmission of message

- Freeze display  
The numeric display reading can be programmed to 'freeze' when RS232 option is selected in ext menu.
- Display frozen and updated by each freeze = RS232  
<Send Measurement> command on RS232 interface in ext menu

# 8.0: Input/Output Connections

Allows remote switches or inputs to be used in place of Digital Readout keys and displayed value to be frozen. Range Lamp status can be used to control external relays.

- Input/Output (25 way D-sub Male connector)

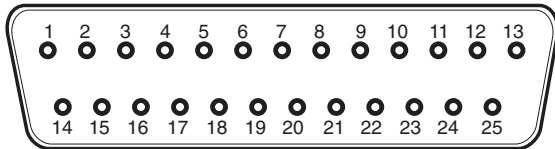

Viewed from rear of unit.

### Inputs

High +3.9V to +15V (max)

Low -0.5V to +0.9V(lo ~5mA)





Pin	Function
2	Remote ZERO
3	Remote LOAD
4	Remote PRINT
5	Remote Reset MAX/MIN/DIFF registers
6	Remote display MAX/MIN/DIFF/ACTUAL, key press cycles
7	Remote Freeze Display
8	Remote Program Up
9	Remote Program Down
22	Remote MOTOR ▲
23	Remote MOTOR ▼
24	Unassigned
25	Unassigned

## 8.0: Input/Output Connections (Continued)

---

- Remote ZERO: Performs same function as pressing **zero** key when input is taken low then high.
- Remote LOAD: Performs same function as pressing load soft key when input is taken low then high in Operation mode preset or Max/min menu.
- Remote PRINT: Performs same function as pressing **print** key when input is taken low then high.
- Remote MAX/MIN/DIFF: Performs same function as pressing soft key that cycles through actual/maximum/minimum/difference in Operation mode Max/min menu, when input is taken low, then high.
- Remote RESET: Performs same function as pressing reset soft key in Operation mode Max/min menu, when input is taken low, then high.
- **Remote Freeze**  
The Digital Readout can be programmed to freeze the displayed reading as follows:
  - Display frozen and updated by each negative going edge on Remote Freeze Display signal.  
freeze = remote neg edge in ext menu.
  - Display frozen while Remote Freeze Display signal is low.  
freeze = remote low in ext menu.

# 8.0: Input/Output Connections (Continued)

- Remote Program Up/Down performs the same function as pressing the **program**  keys when input is taken low then high.
- Motor  /Motor  performs the same function as pressing the **motor**   keys when input is held low.
- Input Schematic**

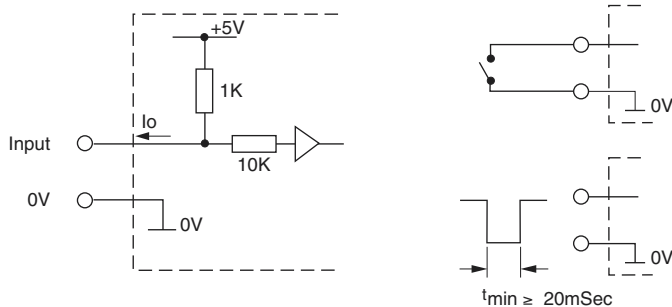

- Active low, edge triggered.
- Only one input to be active at a time.
- If a series of functions is being processed then  $t_{min}$  may be prolonged.

## Outputs

- High +32V (max)  
 $I_c \leq 10\mu A$
- Low  $\leq +0.4V$   
 $I_c \leq 100mA$

Pin	Function
15	Not assigned
16	Range lamps: Within tolerance
17	Range lamps: Low
18	Range lamps: High
19	Do not connect
20	Do not connect

## 8.0: Input/Output Connections (Continued)

- Misc.

Pin	Function
1	0V
10	0V
11	Unused
12	Unused
13	Unused
14	Unused
21	Unused

- Output schematic

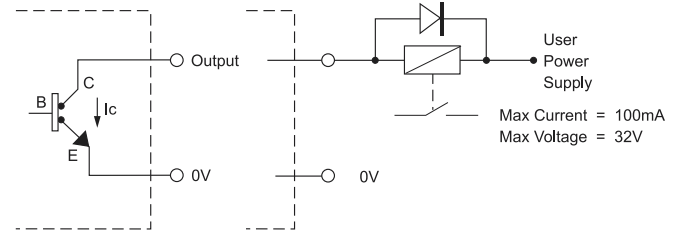

- Open Collector, active low
- Range lamps within tolerance/low/high operate on actual limit set values with no hysteresis
- Delay until signal output:  $\leq 50\text{mSec}$   
(If a series of functions is being processed this may be prolonged)



## 9.0: Motor Drive Connections

Provides dc power for probe motor drive.

Pin	Function
1	Motor +
2	Motor -
3	12V
4	0V
5	Spare

5 Way DIN female connector viewed from rear of unit.

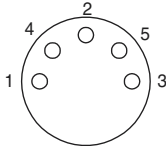

- When  key or remote Motor ▲ selected then  
Motor + = 0V  
Motor - = +12V

- When  key or remote Motor ▼ selected then  
Motor + = +12V  
Motor - = 0V
- When no motor keys or inputs selected then  
Motor + = 0V  
Motor - = 0V
- Maximum current from +12V is 100mA

# 10.0: General Specification

---

## ENVIRONMENTAL

<b>Operating Temperature (°C)</b>	0 to 40 deg. C
<b>Storage Temperature (°C)</b>	-20 to 60 deg. C
<b>Humidity</b>	0 to 95% non condensing
<b>Safety Rating</b>	EN61010-1

## IP Rating

Front panel module	IP65
Complete unit	IP40

## EMC

Emission	EN50081-1
Immunity	EN50082-2

<b>Power supply</b>	via IEC 320 Connector
<b>Line voltage</b>	85V to 264V
<b>Line frequency</b>	47Hz to 440Hz
<b>Power</b>	15W max
<b>Line fuse</b>	2A T
<b>Fuse size</b>	20mm

## Nominal Dimensions

Width	235mm	
Height	80mm	(96mm incl. feet)
Depth	190mm	
Weight	2.3kg	

# 11.0: Return of Goods

---

Devices returned for repair should be shipped prepaid to your Solartron dealer. The shipping container should be marked: “Return for Repair” Model..... Type.....

The following information should accompany the device:

1. A purchase order, unless the device is being returned under warranty.
2. Application, type of environment and length of time in service of the device.
3. Description of the faulty operation of the device and the circumstances of the failure.
4. Name and telephone number of the person to contact if there are questions about the returned device.
5. Statement as to whether warranty or non-warranty service is required.
6. Complete shipping instructions for the return of the device.

7. Original purchase order number and date of purchase.

Adherence to these procedures will expedite handling of the returned device and will prevent unnecessary additional charges for inspection and testing to determine the condition of the device.

Solartron reserve the right to repair or replace goods returned under warranty.

# SOLARTRON METROLOGY OFFICES

## OFFICES WORLDWIDE - Addresses for Repairs

### France

Solartron Metrology,  
Z.I. du Bois Chaland,  
2, rue du Bois Chaland,  
CE 5611 LISSES  
91056 EVRY CEDEX

Tel: +33 (0)1 69 64 47 47

Fax: +33 (0)1 69 64 47 49

### Germany

Solartron Metrology,  
Wittekindstrasse 12  
45470  
Mülheim/Ruhr.

Tel: +49 (0) 208 31026

Fax: +49 (0) 208 31441

### United Kingdom

Solartron Metrology,  
Steyning Way,  
Bognor Regis,  
West Sussex. PO22 9ST

Tel: +44 (0) 1243 825011

Fax: +44 (0) 1243 861244

### U.S.A.

Solartron Metrology,  
10770 Hanover Road,  
Forestville, NY 14062

Tel: +1 (716) 965-4100

Fax: +1 (716) 965-4144

Email: [sales@solartronmetrology.com](mailto:sales@solartronmetrology.com)

Web: [www.solartronmetrology.com](http://www.solartronmetrology.com)

The logo for Solartron, featuring the word "solartron" in a bold, green, sans-serif font.